

SAVE has been designed for controlled and safe sampling of pulp slurry.

SAVE's head is shaped and dimensioned to ensure a representative sample. The sampler head is inserted deep into the process pipe, past the water layer flowing along the pipe wall.

SAVE's interior parts can be flushed with water after the sample has been taken, to prevent build up or blockage of sampler. Since the sampling valve's shut-off mechanism is at the head of the sampler, SAVE will not get blocked even during long duty intervals.

SAVE's piston utilizes metal-to-metal sealing and does not include any wearing parts, such as rubber seals.



TECHNICAL SPECIFICATIONS

Applicability

- Consistency range 0...8 % Cs

Process pressure

- Minimum process pressure for different consistencies: refer to Fig 1
- Maximum process pressure: 2,5 MPa (25 bar), except when coupling material is fibreglass-reinforced plastic: 1,6 MPa
- Pneumatic actuator has a return spring that shuts the valve when pressure is lost.

Supply air pressure p_s (AD actuator)

- $p_{s \text{ min}} = 1/3 \times \text{process pressure}$;
- $p_{s \text{ max}} = 1,0 \text{ MPa (10 bar)}$

Max. discharge rate of pulp

- at different process pressure: refer to Fig. 2.

Connectors

- Water flushing connector: G1/4
- Pneumatic connections for cylinder and regulating valve: G1/8 (5 pcs)

Materials

- Parts in constant contact with process medium: refer to Selection Chart
- Other parts: EN 1.4404 (AISI316L)
- Pneumatic cylinder: aluminium alloy
- Piston rod: hard chrome plated steel

Selection Chart

SAVE

Types

- SA** Clamp mounting NS40
- TA** 1 1/2 - NPS thread
- FA** Flange mounting DN40

Material for closing mechanism ¹⁾

- 2** EN 1.4404 (AISI316L)
- 3** EN 2.4819 (Hast.C276)
- 6** EN 3.7035 (Titaani Ti-II)

Material for process coupling

- 2** EN 1.4404 (AISI316L)
- 3** EN 2.4819 (Hast.C276)
- 6** EN 3.7035 (Titanium Ti-II)
- 9** Fibreglass-reinforced plastic

Function

- MD** Manual
- AD** Pneumatic

Open / closed detector

- 0** None
- 1** Yes (for pneumatic actuator only)

¹⁾ Only parts in constant contact with process medium; other parts always EN 1.4404 (AISI316L)

Weight	Function	
	MD	AD
SAVE SA	1.9 kg	2.1kg
SAVE TA	1.7 kg	1.9 kg
SAVE FA	5.0 kg	5.2 kg

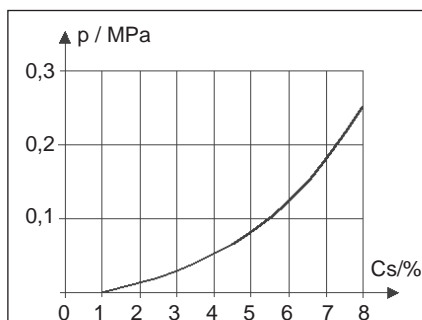
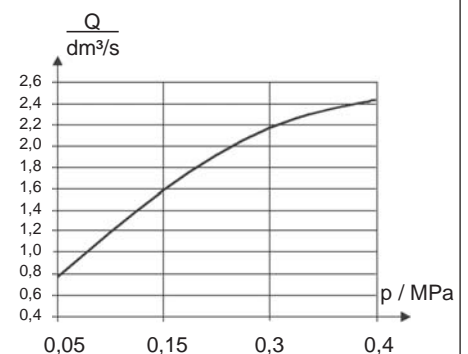

Figure 1 Minimum process pressure at different consistencies

Pulps:
 - long-fibered chemical pulp } Cs = 0...4 %
 - groundwood pulp }
 - recycled fibre pulp }
 - short-fibered chemical pulp }

-TMP } Cs = 0...2 %
 -CTMP }



At higher consistencies the sample discharge rate is lower.

Figure 2 Maximum discharge rate of pulp at different process pressures with maximum valve opening.

Dimensions (are in mm)

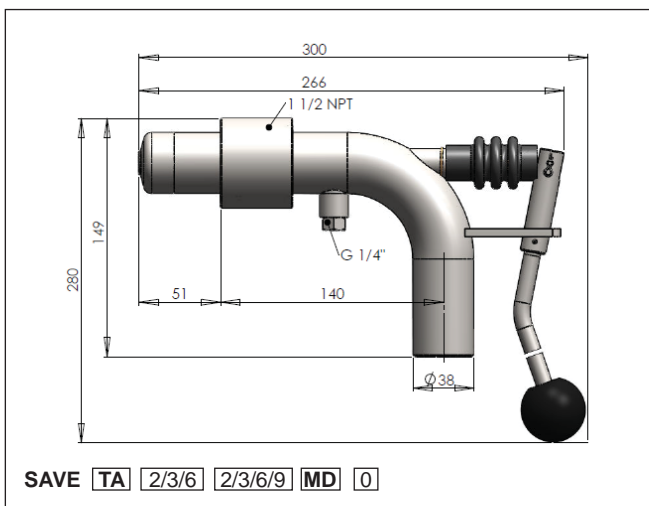
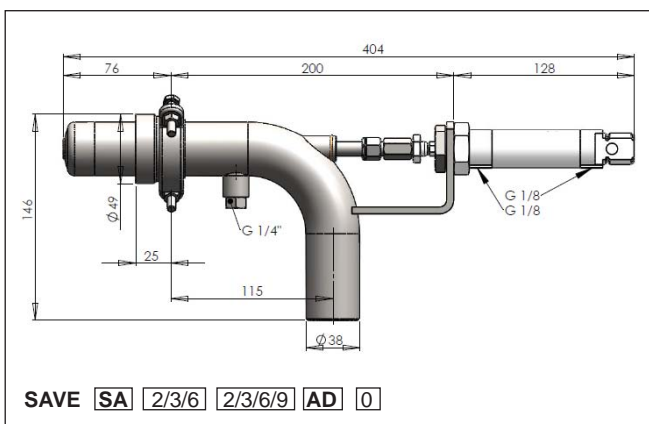
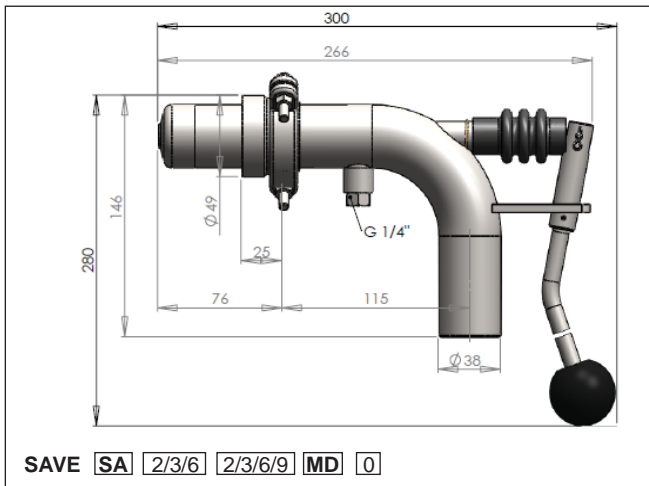

European Directive Information

Machinery Directive 2006/42/EC

- Available only for SAVE sampler with the pneumatic cylinder (AD)
- Assessment of conformity with internal checks on the manufacture of machinery.

Pressure Equipment Directive (PED) (97/23/EC)

- Sound Engineering Practice

Installation

SAVE is mounted at a point in the process line that will provide a representative sample. It must not be installed in a dead zone of flow. Refer to the illustrations and instructions

in SAVE sampler's user's guide (document G800AV).

SAVE is mounted is an opening made on the process pipe through a process coupling selected in accordance with the Selection Chart. TA and SA couplings are welded on the process pipe, while FA type is laminated on plastic process pipe.

After SAVE has been mounted on the process pipe you attach the supplied 400 mm plastic discharge tube with a hose clamp. This will ensure that the sample will not splash.

Flushing with water is recommended in all installations. For this purpose a waterline equipped with a shutoff valve is needed to be connected to the sampler. Samplers with Titanium or Hastelloy C276 wetted parts flushing must be connected to prevent corrosion of the samplers interior parts.

Solenoid valves (SAVE AD) must be equipped with restrictors at outlet side to dampen the piston movement.

NOTE!

If the process pressure exceeds 1,0 MPa (10 bar) the strength of the connection between process coupling and process pipe has to be calculated separately in accordance with the pipework's pressure endurance. If necessary, the connection must be reinforced.

Mounting SAVE with pneumatic cylinder (Function AD)

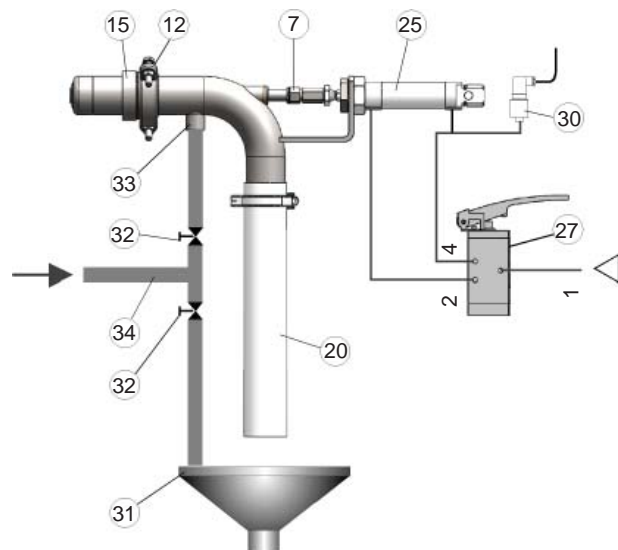

7. Stop nut
12. Mounting clamp
15. Process coupling
20. Discharge tube
25. Actuating cylinder
27. Manually operated compressed air valve
30. Valve OPEN / CLOSED detector assy ¹⁾
31. Overflow tunnel ²⁾
32. Water valve ¹⁾
33. Water flushing connection
34. Water pipe ²⁾

¹⁾ Is supplied on special order

²⁾ Not supplied with SAVE