

Installation and Setting-Up Instructions Spare Parts List



Contents:

- 1 Purpose of Use**
- 2 Types and Applications**
- 3 Installation**
 - 3.1 Choosing the mounting location
 - 3.2 Installing the process coupling
 - 3.3 Mounting SAVE
- 4 Sampling**
- 5 Maintenance**
- 6 Structural drawings, parts list and spare parts list**

Appendix: Technical Specifications G800

DOCUMENTS

Technical Specifications: G800

Installation and Setting-Up Instructions: G800AV

We reserve the right for technical modifications without prior notice.
Hastelloy® is the registered trademark of Haynes International.
Teflon® E.I. is the registered trademark du Pont de Nemours & Co.
Viton® is the registered trademark DuPont Down Elastomer.



Satron Instruments Inc.

P.O.Box 22, FIN-33901 Tampere, Finland
Tel.int. +358 207 464 800, Telefax +358 207 464 801
www.satron.com, info@satron.com



Conmark Systems Inc. Instruments Div.
Atlanta, GA 770-300-0224
www.conmark.com

SAVE Sampler

1. Purpose of use:

SAVE has been designed for the sampling of pulp slurry. SAVE is suitable for all chemical and mechanical pulps and recycled fibre pulps. SAVE is installed directly on the process pipe.

2. Types and applications

Refer to the selection chart in Technical Specifications. The construction of different types is shown in Figures 6-1 ...6-4 in Section 6.

SAVE is available in three types, depending on the mounting method: clamp-, thread- and flange-mounted types. All types are available with either manual or pneumatic cylinder, see Figures 6-1 and 6-2.

Figures 6-1 and 6-2 show clamp-mounted SAVE types with NS 40 flanges. Figure 6-3 shows SAVE TA with 1½" NPT thread mounting.

The SAVE FA with fibreglass-reinforced plastic coupling, Figure 6-4, has been designed for mounting on a fibreglass-reinforced plastic process pipe.

Manually operated SAVE is suitable for easily. The pneumatically operated type is also suitable for locations of difficult access. In this case the sample is run from SAVE to a sample receptacle through a sufficiently long discharge tube or pipe. The pneumatically operated sampler is controlled with a control valve mounted close to the sampler or through remote control. The pneumatically operated type can also be used for automatic sampling.

Material options for parts in constant contact with process medium include AISI316L (EN 1.4404), Hastelloy C276 (EN 2.4819) and Titanium (EN 3.7035). The flange-mounted SAVE FA has a fibreglass-reinforced plastic process coupling.

AISI316L suits a majority of applications.

Titanium is recommended for bleaching stages that use chlorine or chlorine compounds. Peroxide bleaching stages and applications where free chlorine gas may occur are an exception. Hastelloy C276 should be used in such applications.

3. Installation

3.1 Choosing the mounting location

SAVE's mounting location is selected as shown in Figures 3-1a, b and c. When installed in this way, the delay between consistency transmitter and sampling point will be as small as possible and a representative sample will be obtained from the pipe.

When SAVE is installed immediately after stock pump, it should be mounted on the side shown in Figure 3-1a a relative to the position of the pump. There should be a 45° - degree angle from the pump shaft on the side where the pulp rushes from the pump.

- 1) Refer to consistency transmitter's installation instructions.

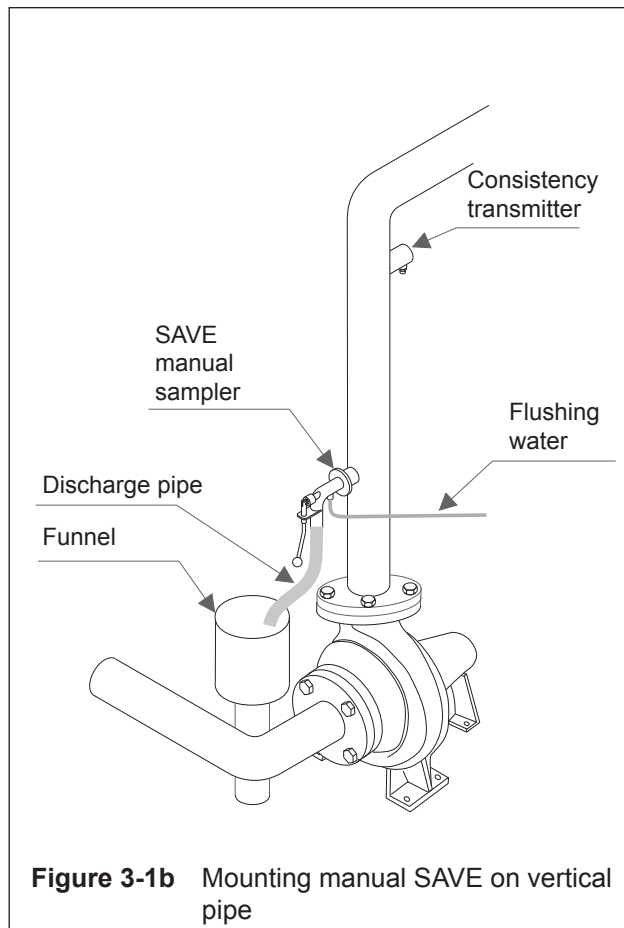
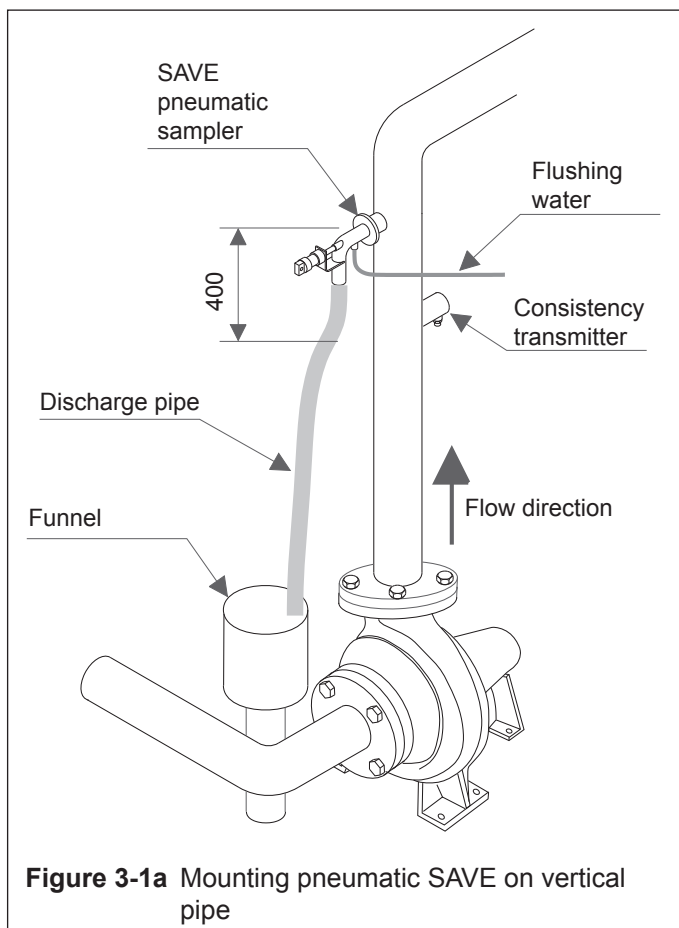

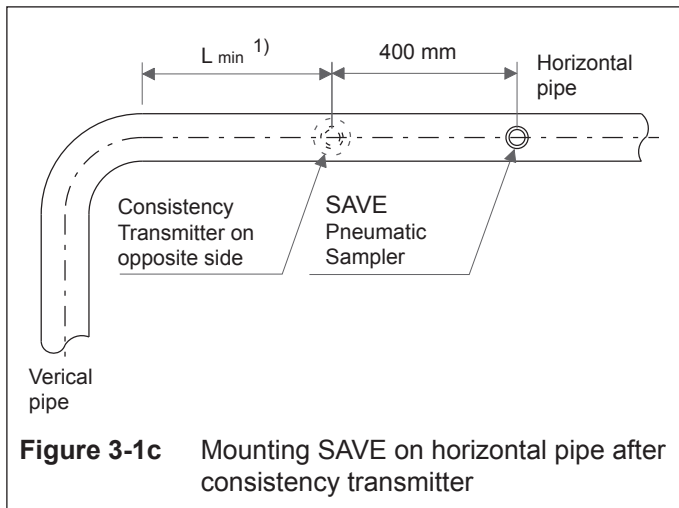

1) Refer to consistency transmitter's installation instructions.

3.2 Installing the process coupling

The safety requirements should be observed when installing process couplings. The installation should be performed by a skilled fitter.

3.2.1 Coupling for clamp mounting, Figure 3-2a

Make a 50 mm hole with V-bevelling on the process pipe. Place the coupling in the hole so that edges A are on a level with the pipe's inner surface (Note: the process coupling's straight edge need not be machined to curve shape). Weld the coupling as shown in Figure 3-2a.

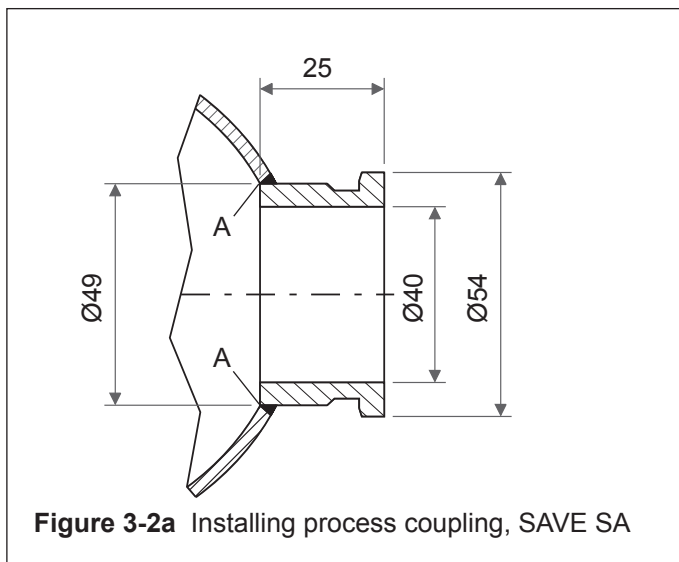

3.2.2 Process coupling with 1½ - 11½ NPS, Figure 3-2b

Make a hole with V-bevelling on the process pipe. The diameter of the hole should be approx. 1 mm larger than the coupling's outside diameter ØD. Recommendable length of the coupling is L = 35 mm. Weld coupling as shown in Figure 3-2b.

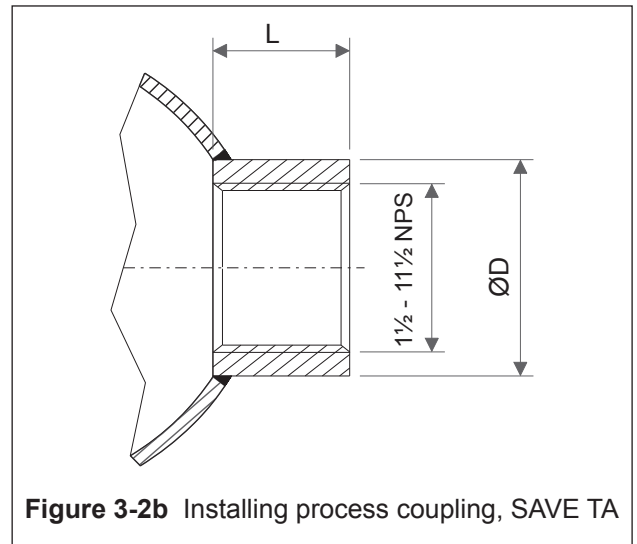

3.2.3 Fibreglass-reinforced plastic flanged coupling, Figure 3-2c

Make in the fibreglass-reinforced plastic process pipe a hole to suit the coupling. Laminated the coupling in position as shown in Figure 3-2c.

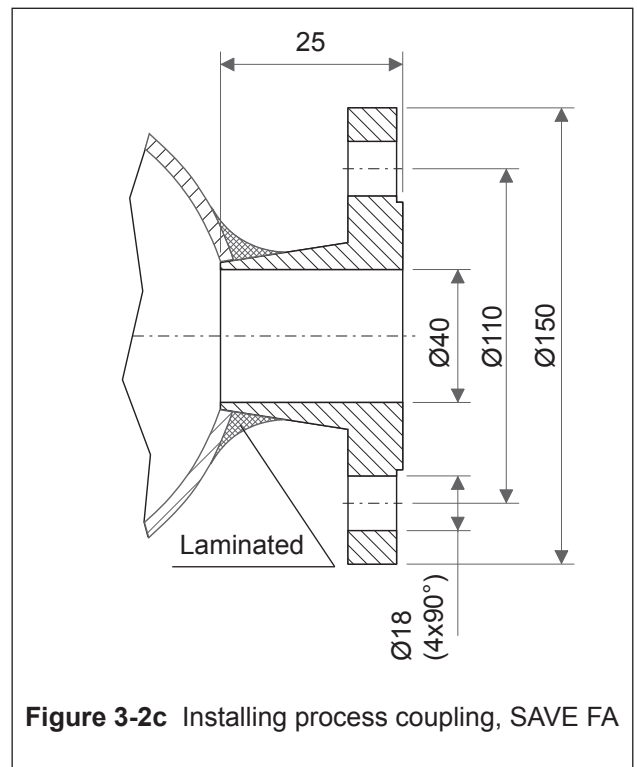

SAVE Sampler

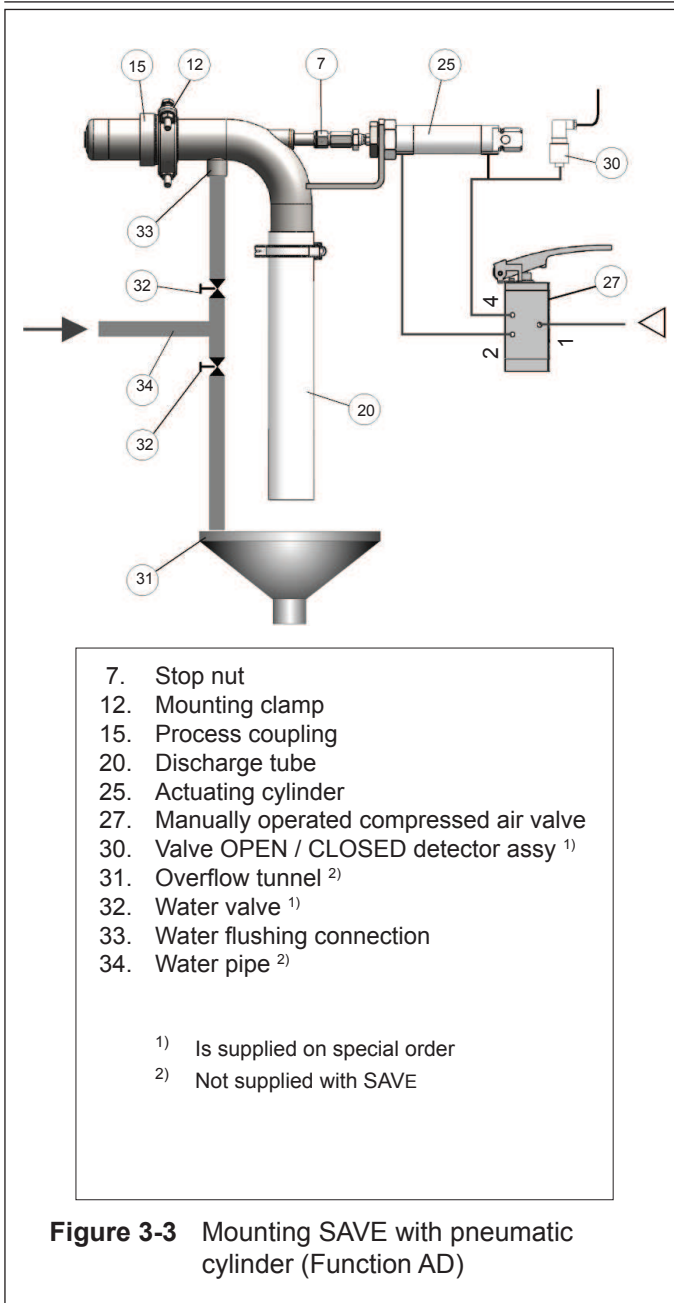

Figure 3-3 Mounting SAVE with pneumatic cylinder (Function AD)

3.3 Mounting SAVE

SAVE SA

First place the PTFE coupling seal in its groove. Then mount SAVE SA with clamp (12) as shown in Figures 3-3, 6-1 and 6-2. Apply 6,5Nm force to tighten the screws.

SAVE TA

Apply locking medium (e.g. Loctite 572) to SAVE TA's thread. Then screw SAVE by **hand** into coupling so that the discharge tube will be downwards.

SAVE FA (with plastic process coupling)

Use four M16 screws to mount SAVE FA with PTFE seal. Be careful not to tighten the screws excessively.

Using sample discharge tube (or pipe)

(20) in Figures 3-3, 6-1, 6-2 and 6-3
 Attach the supplied plastic discharge tube with hose clamps as shown in figures.

In this way the sample can be taken out without splashing. If SAVE is installed at the location with difficult access e.g. at a great height in the pipework, you have to use a longer discharge tube or metal pipe (Figure 3-3). Install a funnel below the sampling point. To prevent overflowing pulp from getting to the floor, install a pipe having at least 60 mm diameter from the funnel to sewer.

3.3.1 Pneumatic installations (function AD)

Pneumatic connections are made as shown in Figure 3-3, connections G1/8.

The manually operated compressed air valve (27) is mounted with two M6 screws on wall or mounting bracket.

3.3.2 Connection for water flushing (33), Figure 3-3

SAVE has an G $\frac{1}{4}$, flushing connector that allows the connection of a pressure-water pipe equipped with a shutoff valve.

Flushing should be used to ensure a representative sample and to prevent clogging. Flushing may only be omitted in cases where pulp will not dry and accumulate inside SAVE and where representativeness is not such a critical factor.

If SAVE's material is Titaani or Hastelloy, flushing should always be used to avoid corrosion.

3.3.3 Closed/Open detector (30), Figure 3-3

SAVE function AD is also supplied with a pressure switch that provides a binary signal to the system from sampling moment.

4 Sampling

4.1 Preparing SAVE

Adjust the stop nut (7, 14 mm jaw width, Figure 3-3, 6-1, 6-2 and 6-3) to adjust the valve stroke for 1.0 to 1.5 l/s sample discharge rate. If the valve stem is adjusted for maximum opening, the discharge rate may also be less than 1 l/s.

4.2 General instructions

Use at least 1-litre sample receptacles equipped with cover. Transport the receptacles in a basket suitable for the purpose. Before beginning to take consistency samples, make sure that consistency level stays as stable as possible.

To get representative average consistency sample from the process, we recommend that you take 3 to 5 samples at e.g. 30 second intervals. The laboratory will then analyze the consistency of each sample separately. Another method to obtain a good average consistency sample is to run out 5 to 10 litres of pulp at a time and take a sample from this amount for laboratory analysis in accordance with the TAPPI, T240 standard. (The pulp should be well mixed when taking the sample).

4.3 Procedure

- Write down the consistency transmitter's output.
- First allow some of the sample to run past the reseptacle.
- Take a suitable portion of sample flow into the receptacle, so that the receptacle is filled in a controlled manner without overflowing. Do not pour out any pulp from the receptacle, because then would change the sample's consistency. If any overfilling occurs, pour out the entire sample and take a new sample
- Flush SAVE

- Put cover on the sample receptacles and take the receptacles to laboratory for consistency analysis.
- Perform consistency analysis in accordance with mill-specific instructions or general standard (e.g. TAPPI, T240) . If the pulp contains fillers, also perform ash analysis e.g. in accordance with TAPPI T211.

4.4 Automatic sample taking

SAVE (function AD) can be used for automatic sample taking, for instance when wanting to observe the average consistency over a specific period of time from n samples. SAVE's discharge tube is then directed to a large-volume receptacle equipped with a cover.

Note: Flushing cannot be used in this case. However, the pulp will not dry in the channels because the end of the discharge tube is in a receptacle has a cover, and even under the surface of the sample pulp.

The sampling times and sample volumes can be determined with a local timer through a solenoid valve or by means of remote control.

Adjustable restrictors must be used at the exhaust air side to attenuate the plunger stroke.

5. Maintenance

SAVE does not require regular servicing.

Replacing valve shaft (4)

- SAVE function MD, Figures 6-1 and 6-3
 Remove the pivot pin cotter (19) and pivot pin (8). Make sure that the spring (16) and guide sleeves (5) come out in a controlled manner. Unscrew the stop nut (7). Replace the valve shaft with a new one.
- SAVE function AD, Figure 6-2
 Heat extension nut (24) to soften the locking medium in the thread. Then unscrew the coupler. While doing this, keep hold of the compressed-air cylinder's piston. Avoid overheating. Unscrew the stop nut (7). Replace the valve shaft and reassemble the other parts. Apply locking medium (e.g. Loctite 270) to the thread of the extension nut.

Replacing the bearing sleeve (6) and O-ring (23), Figures 6-1, 6-2 and 6-3

With the valve shaft and compressed-air cylinder (function AD) removed, remove the locking ring (17). Remove the bearing sleeve and o-ring. Put in the new o-ring and bearing sleeve.

6. Structural drawings, parts list and spare parts list

Parts indicated with asterisk (*) are spare parts.

When ordering spares, please quote this document's number G800AV 15.09.2013, the name and order number of the required part, and the sampler's serial number.

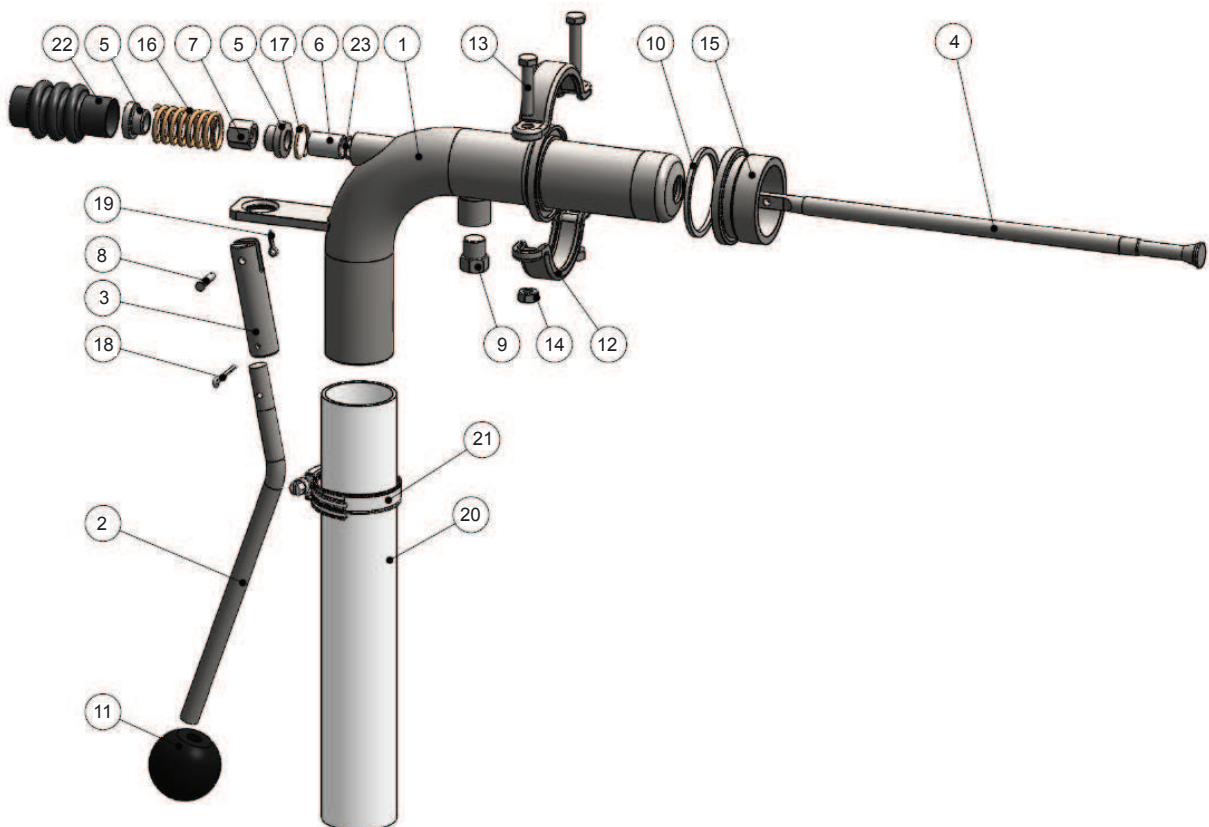

Figure 6-1 SAVE SA 2 2 MD 0

SAVE Sampler

G800AV
Man. revision 1
15.09.2013

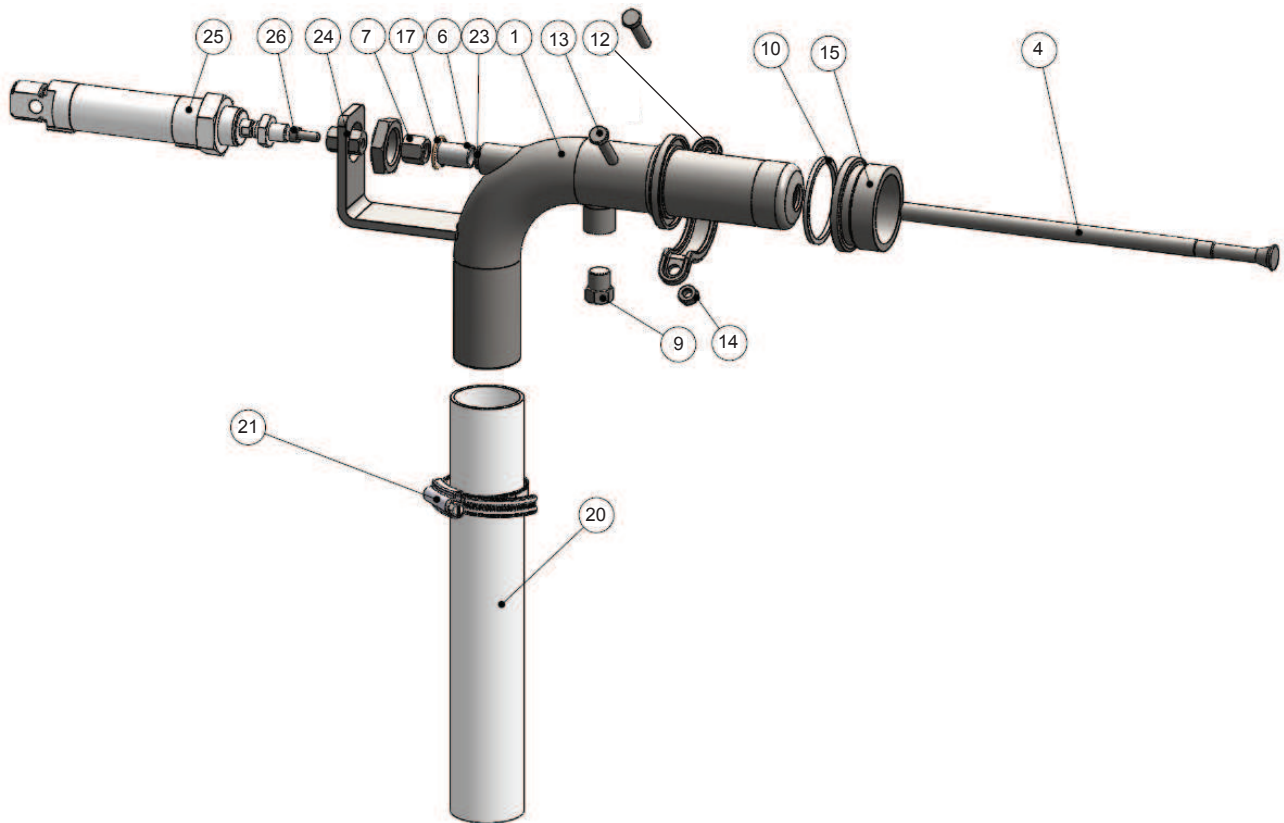

Figure 6-2 SAVE SA 2 2 AD 0

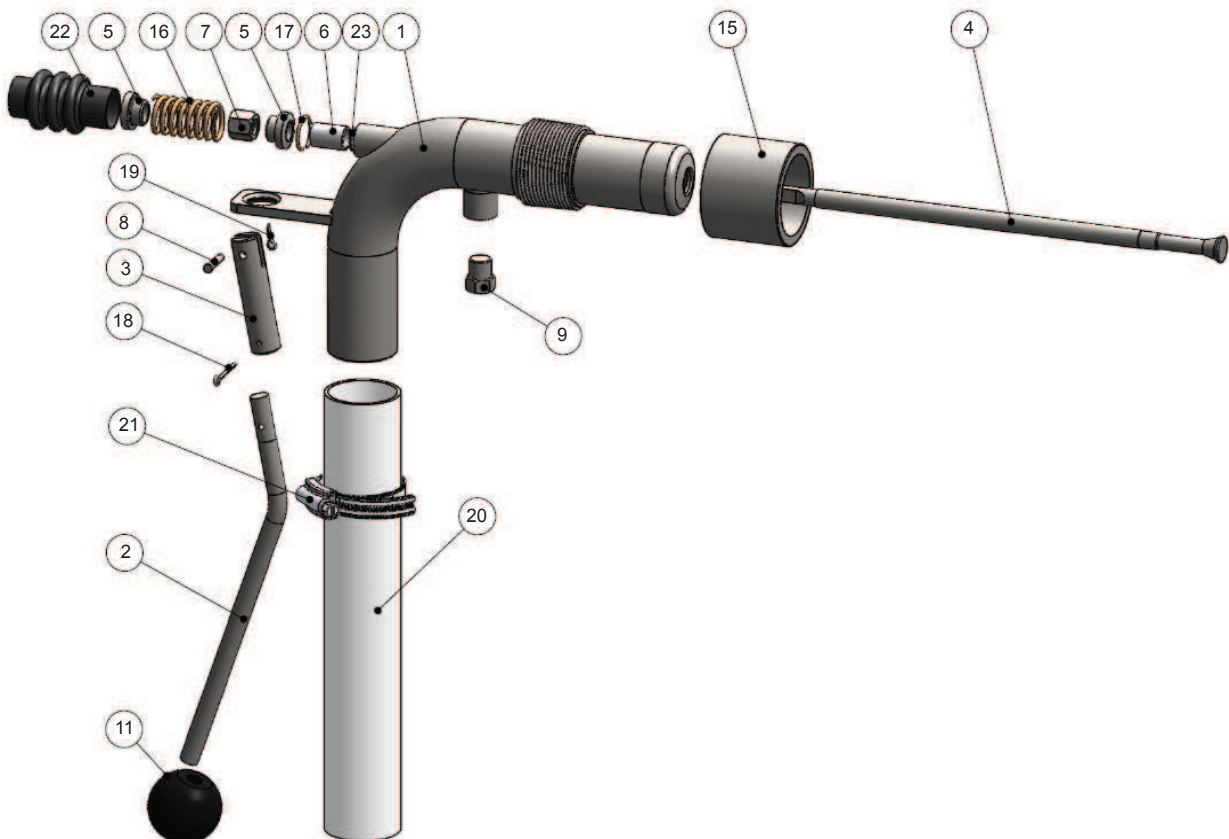

Figure 6-3 SAVE TA 2 0 MD 0

SAVE Sampler

G800AV
Man. revision 1
15.09.2013

No.	Name	Pcs	Order number (AISI316L)
1	Sampler body SAVE SA (MD)	1	T1035002
1	Sampler body SAVE SA (AD)	1	T1035004
1	Sampler body SAVE TA (MD)	1	T1035005
1	Sampler body SAVE TA (AD)	1	-
1	Sampler body SAVE FA (MD)	1	-
1	Sampler body SAVE FA (AD)	1	-
2	Operating handle	1	T1035215
3	Pivot pin	1	T1035205
* 4	Valve shaft MD	1	T1035213
* 4	Valve shaft AD	1	T1035221
* 4	Valve shaft FA MD	1	-
* 4	Valve shaft FA AD	1	-
5	Guide sleeve	1	T1035202
* 6	Bearing sleeve	1	T1035208
7	Stop nut	1	T1035214
8	Pivot pin	1	T1035204
9	Plug G $\frac{1}{4}$	1	T1035209
*10	Seal PTFE SAVE SA	1	T1035210
11	Ball knob	1	81200040
12	Clamp DN40/44,5	2	82220001
13	Hex screw M6 x 25	2	54226030
14	Hex nut M6	2	56022600
*15	Process coupling (SAVE SA)	1	T1035200
*15	Process coupling 1 $\frac{1}{2}$ - 1 $\frac{1}{2}$ NPS (SAVE TA)	1	T1035224
*15	Process coupling DN40 (SAVE FA)	1	-
*16	Valve spring	1	T1035217
17	Locking ring	1	T1035216
18	Cotter pin 2,5 x 25 DIN94 A4	1	57301154
19	Cotter pin 1,5 x 12 DIN94 A4	1	57301152
20	Discharge tube	1	T1035219
21	Hose clamp	1	82220005
*22	Protective bellows	1	80450500
*23	O-ring \varnothing 10,1 x 1,6 FPM	1	80011116
24	Extension nut AD	1	T1035222
*25	Double acting air cylinder	1	82920005
26	Hexagon socket screw M5 x 12 DIN912 A4	1	54425011
*27	Hand-controlled valve 5/2 with mounting bracket	1	82920007

Note!

Parts are made of AISI 316 in the table above, but the material options defined in Technical Specifications are also possible.

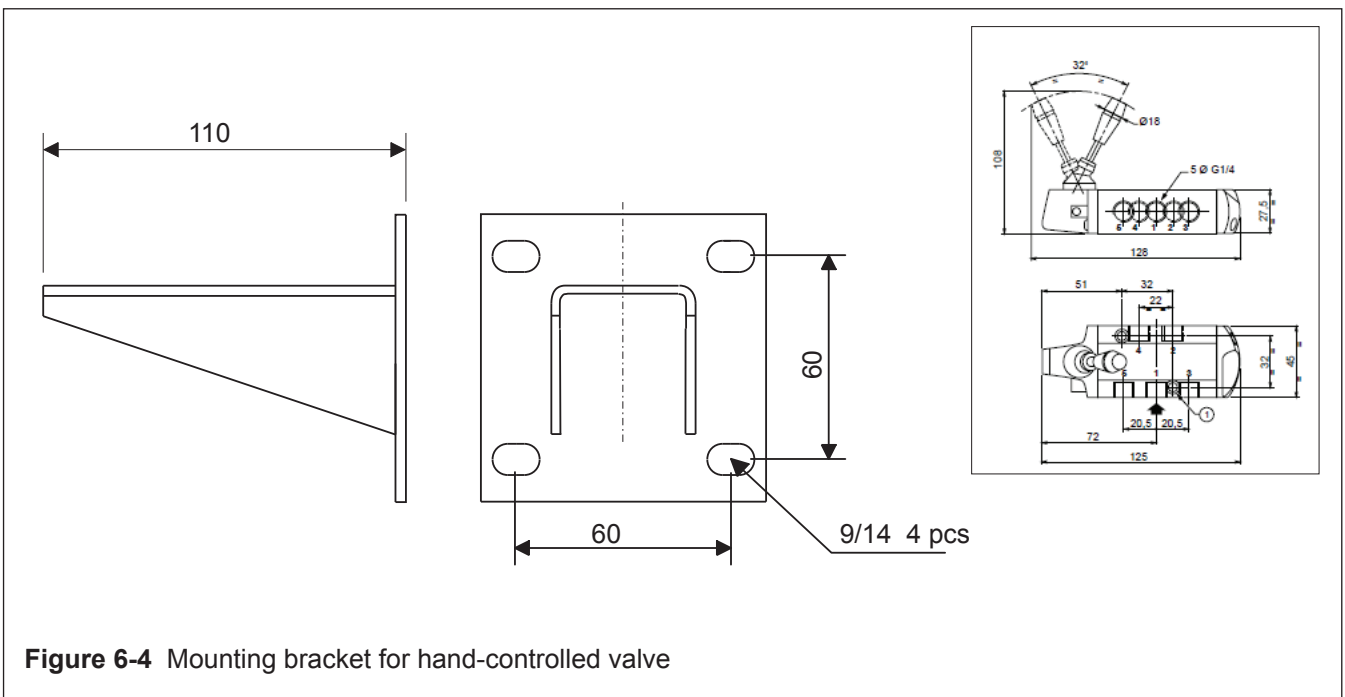

Figure 6-4 Mounting bracket for hand-controlled valve

WARNING!

Make sure always before installation or disconnection
that the process pipe is empty and unpressurized!

Satron Instruments Inc.
P.O.Box 22, FIN-33901 Tampere, Finland
TEL.INT. +358 207 464 800
Telefax +358 207 464 801
www.satron.com, info@satron.com

